

**APPLICABLE CODES**  
SAN MATEO COUNTY

**SITE DATA**

APN: 048-037-050  
ZONING: R-1/8-11(DR)/ 1CD  
OCCUPANCY GROUP: R-3/U  
TYPE OF CONSTRUCTION: V-B

- SAN MATEO COUNTY ZONING AND BUILDING ORDINANCES
- 2013 CALIFORNIA RESIDENTIAL CODE
- 2013 CALIFORNIA BUILDING CODE AND AMENDMENTS
- 2013 CALIFORNIA MECHANICAL CODE
- 2013 CALIFORNIA PLUMBING CODE
- 2011 CALIFORNIA ELECTRICAL CODE
- 2013 CALIFORNIA FIRE CODE
- 2013 CALIFORNIA GREEN BUILDING STANDARD CODE
- 2013 CALIFORNIA ENERGY CODE
- ANY APPLICABLE COUNTY CODES, ORDINANCES OR AMENDMENTS TO THE CALIFORNIA RESIDENTIAL CODE

	EXISTING		PROPOSED		TOTAL		ALLOWED	
	AREA (SQ FT)	%	AREA (SQ FT)	%	AREA (SQ FT)	%	AREA (SQ FT)	%
LOT AREA	5,000	100	-----	-----	-----	-----	-----	-----
PARCEL COVERAGE	1,985 SQFT.	39.70	1,750 SQFT.	35.00	1,750	35.00	1,750	35.0
FLOOR AREA	1,792 SQFT.	36.20	FIRST FLOOR 1750 SECOND FLR 764 LOFT 132 TOTAL 2646	52.96	2646	52.96	2,650	53.0

**DRAWING INDEX**

SHEET	TITLE
A1	COVER SHEET
A2	(E) & (N) SITE PLAN
A3	(E) FLOOR PLAN & DEMO PLAN
A4	(N) FIRST FLOOR PLAN
A5	(N) SECOND FLOOR PLAN
A6	(N) THIRD FLOOR PLAN
A7	(E) & (N) EAST ELEVATIONS
A8	(E) & (N) NORTH ELEVATIONS
A9	(E) & (N) WEST ELEVATIONS
A10	(E) & (N) SOUTH ELEVATIONS
A11	(N) SECTION



**VICINITY MAP**

**SCOPE OF WORK:**

REMODEL (E) LIVING SPACE ON THE LOWER FLOOR, ADD AN UPPER FLOOR LIVING AREA, AND ADD A THIRD FLOOR OFFICE

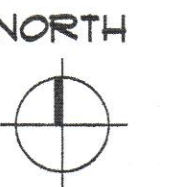

**LEGEND**

- EXISTING WALL
- - - - REMOVE EXISTING WALL
- NEW WALL
- (E) EXISTING
- (N) NEW
- P.T.D.F. PRESSURE TREATED DOUGLAS FIR
- H.B. HOSE BIBB
- DN DOWN
- RWL RAINWATER LEADER
- NIC. NOT IN CONTRACT
- UNO UNLESS NOTED OTHERWISE
- WP WEATHERPROOF
- 6066 6'-0" x 6'-8"
- SS STAINLESS STEEL

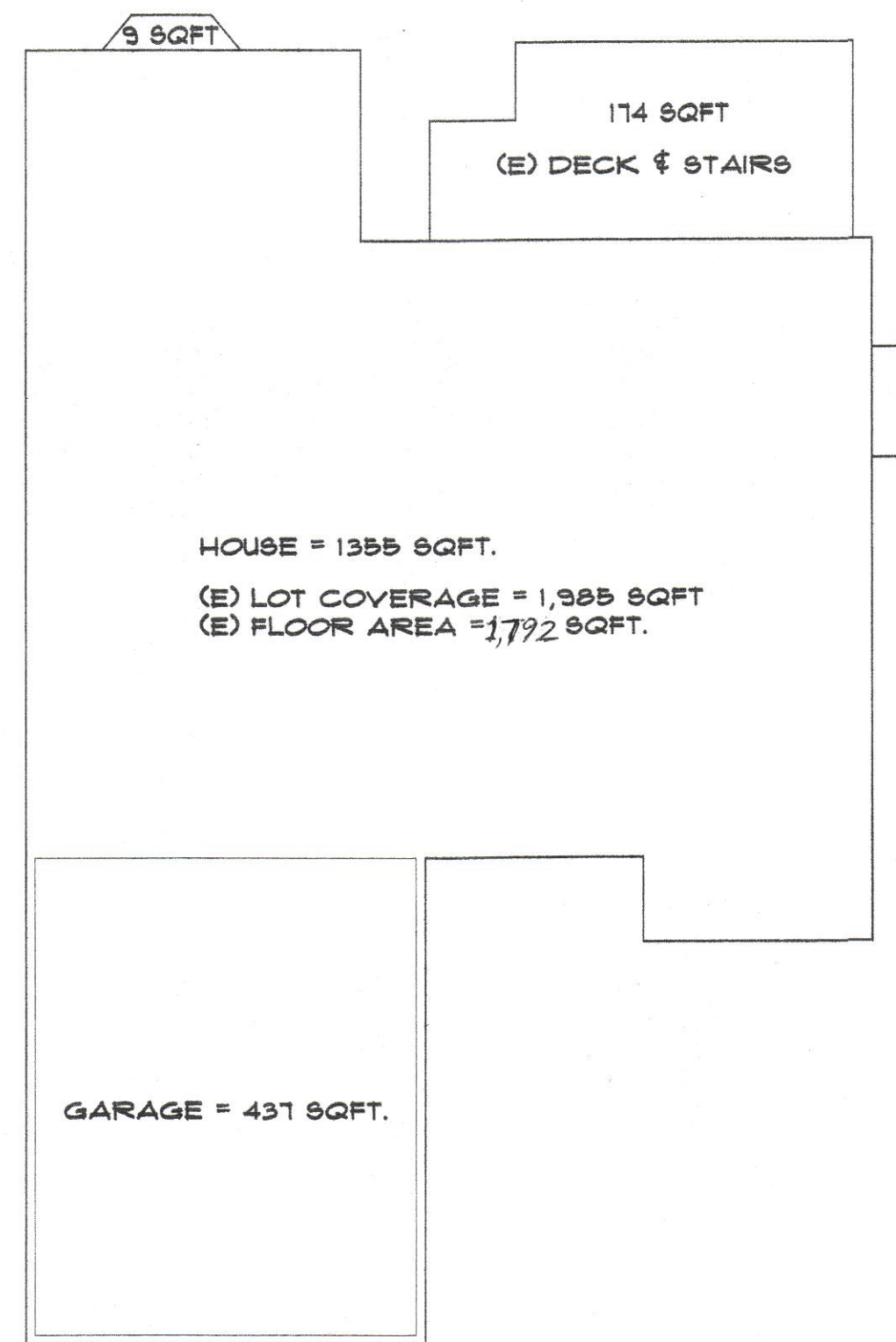
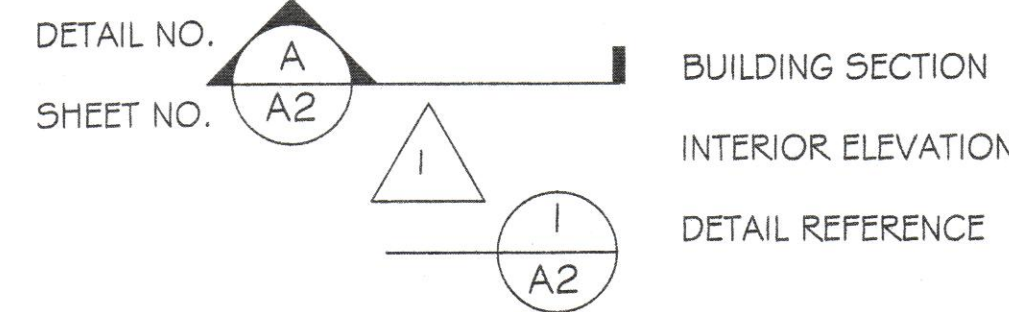

**EXISTING BUILDING OUTLINE**

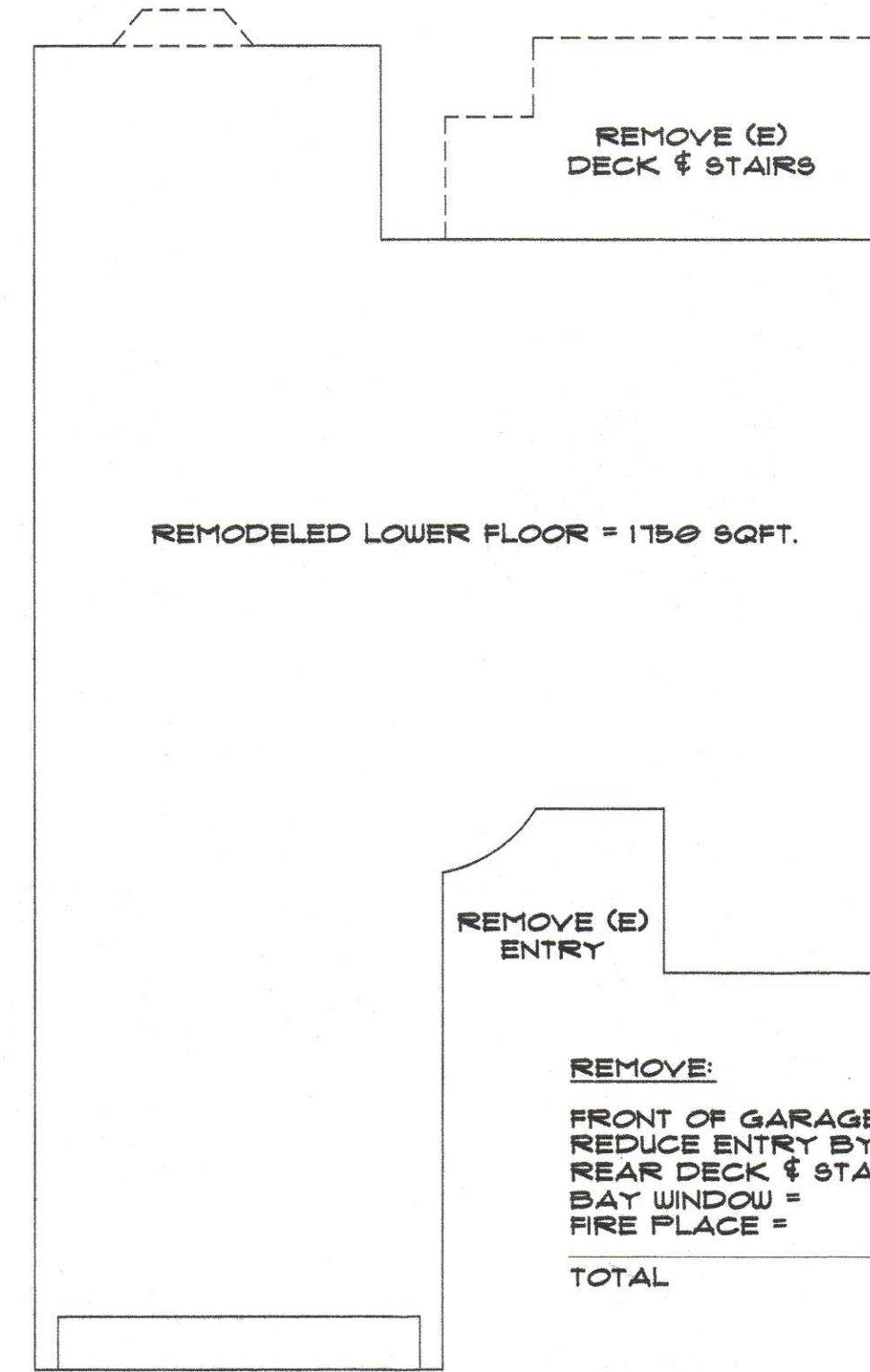

**NEW LOWER FLOOR OUTLINE**

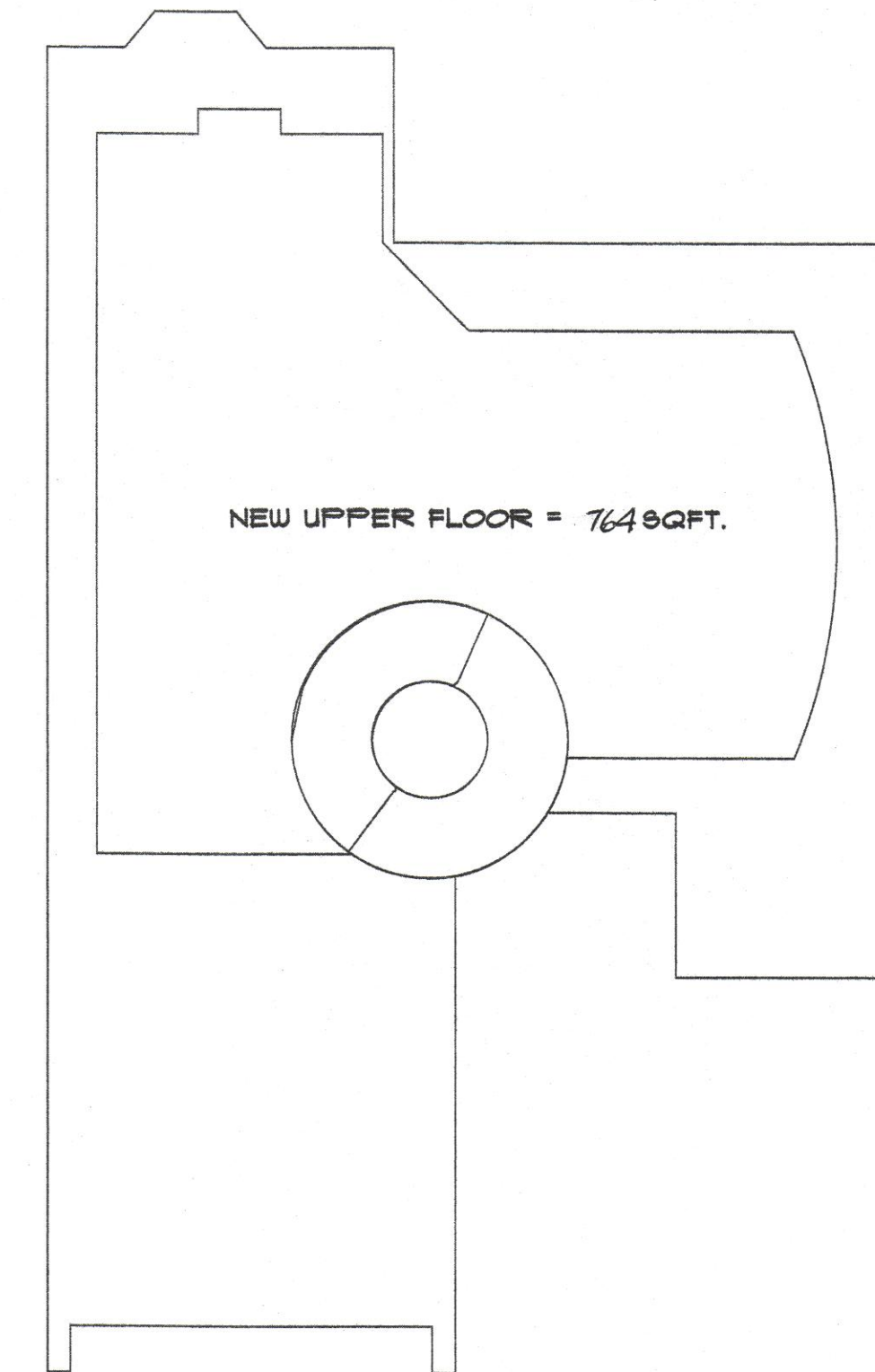

**NEW LOWER FLOOR OUTLINE**

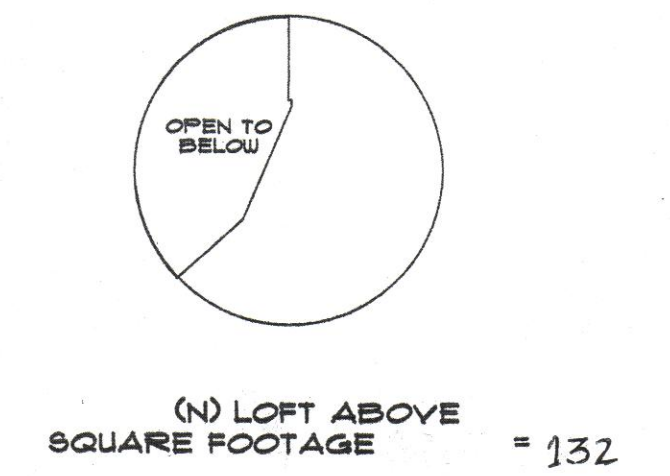

**NEW LOFT ABOVE**

**BUILDING DATA DETAILS**

NO SCALE

**RECEIVED**

MAR 25 2015  
San Mateo County  
Planning and Building Department

PLN2015-00024

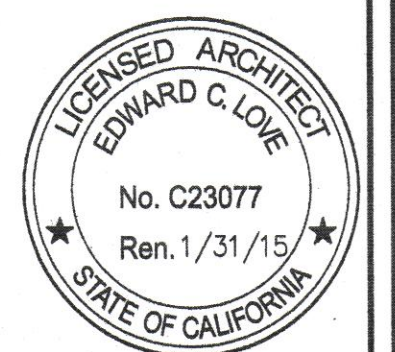

**REVISIONS**

**EDWARD C. LOVE**  
ARCHITECT  
120 MILL STREET  
HALF MOON BAY, CA 94019  
(650) 728-1615  
WWW.EDWARDLOVEARCHITECT.COM

**UPPER FLOOR ADDITION**  
FOR KEEGSTRA & HALL RESIDENCE  
420 3RD AVENUE  
MIRAMAR (HMB), CA 94019

KEEGSTRA & HALL RESIDENCE  
420 3RD AVENUE  
MIRAMAR (HMB), CA 94019

**COVER SHEET, NOTES & LEGEND**

DATE: 1-14-15  
SCALE: AS NOTED  
DRAWN: RLW  
JOB: KEEGSTRA & HALL  
SHEET:

**A-1**



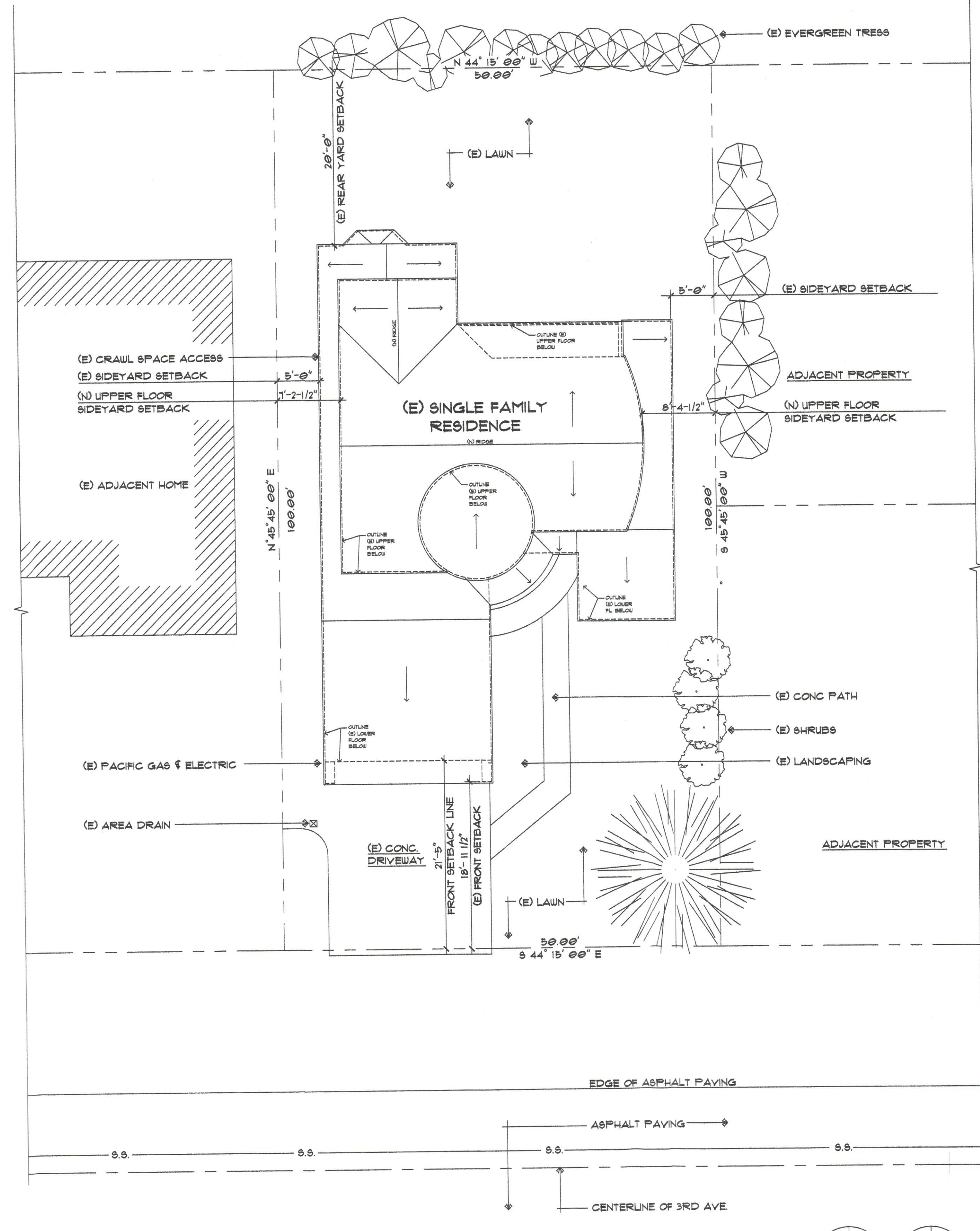
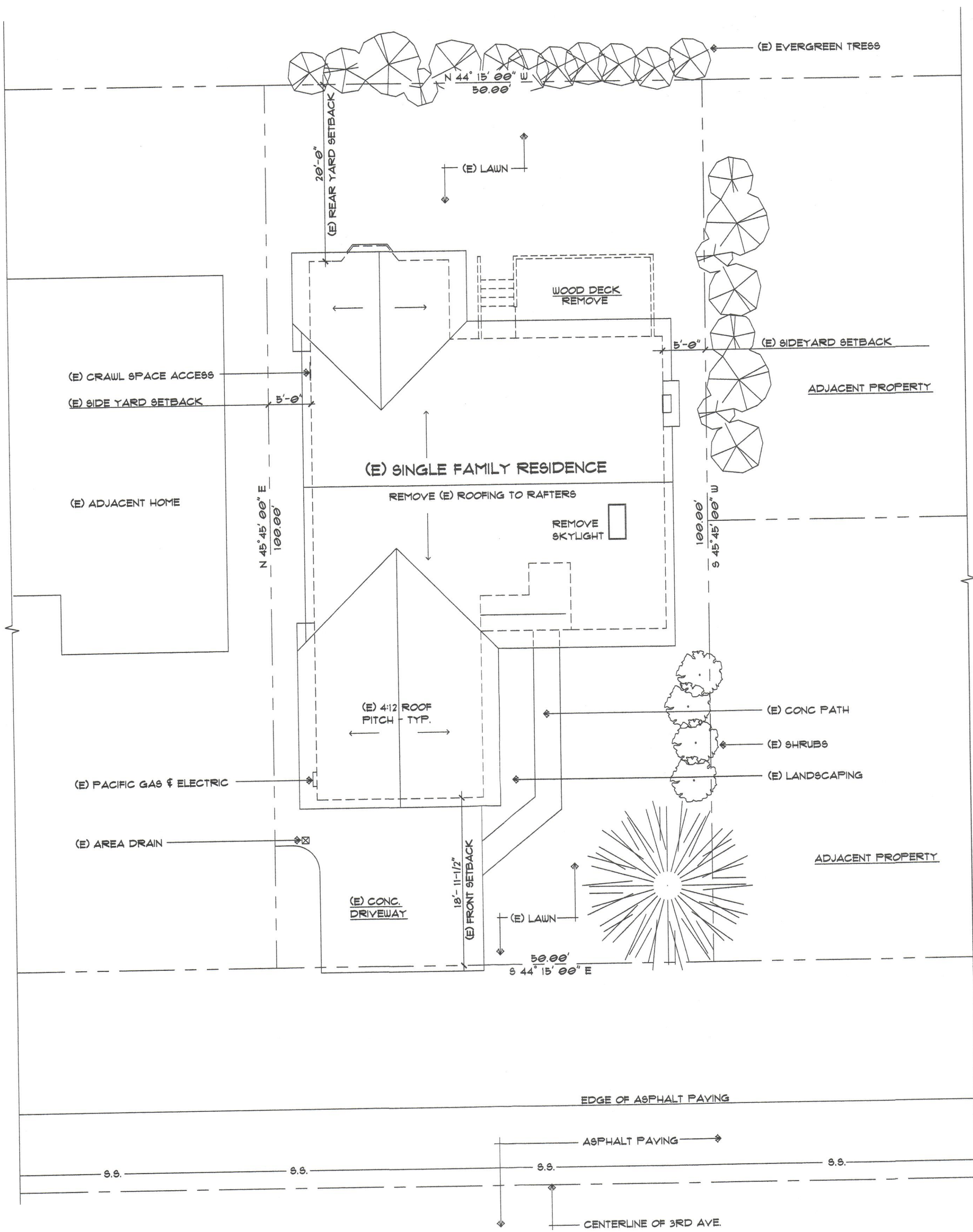

EXISTING SITE & ROOF PLAN - INCLUDES DEMOLITION

NEW SITE & ROOF PLAN

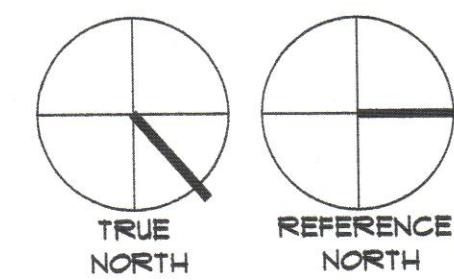
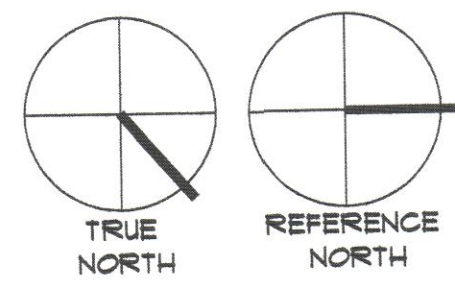

REVISIONS

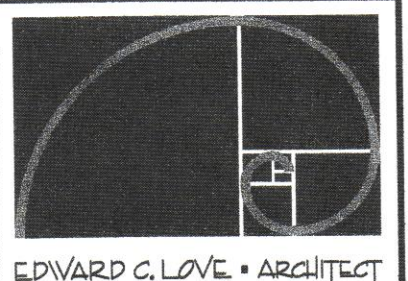

EDWARD C. LOVE  
ARCHITECT  
120 MILL STREET  
HALF MOON BAY, CA 94019  
(650) 728-1615  
WWW.EDWARDLOVEARCHITECT.COM

PROJECT:  
UPPER FLOOR ADDITION  
FOR KEEGSTRA & HALL RESIDENCE  
420 3RD AVENUE  
MIRAMAR (HMB), CA 94019

OWNER:  
KEEGSTRA & HALL RESIDENCE  
420 3RD AVENUE  
MIRAMAR (HMB), CA 94019

(E) & (N)  
SITE &  
ROOF  
PLAN

DATE: 1-14-15

SCALE: AS NOTED

DRAWN: RLW

JOB: KEEGSTRA & HALL

SHEET:

A-2

OF 11 SHEETS

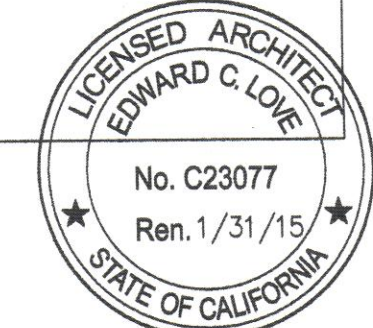



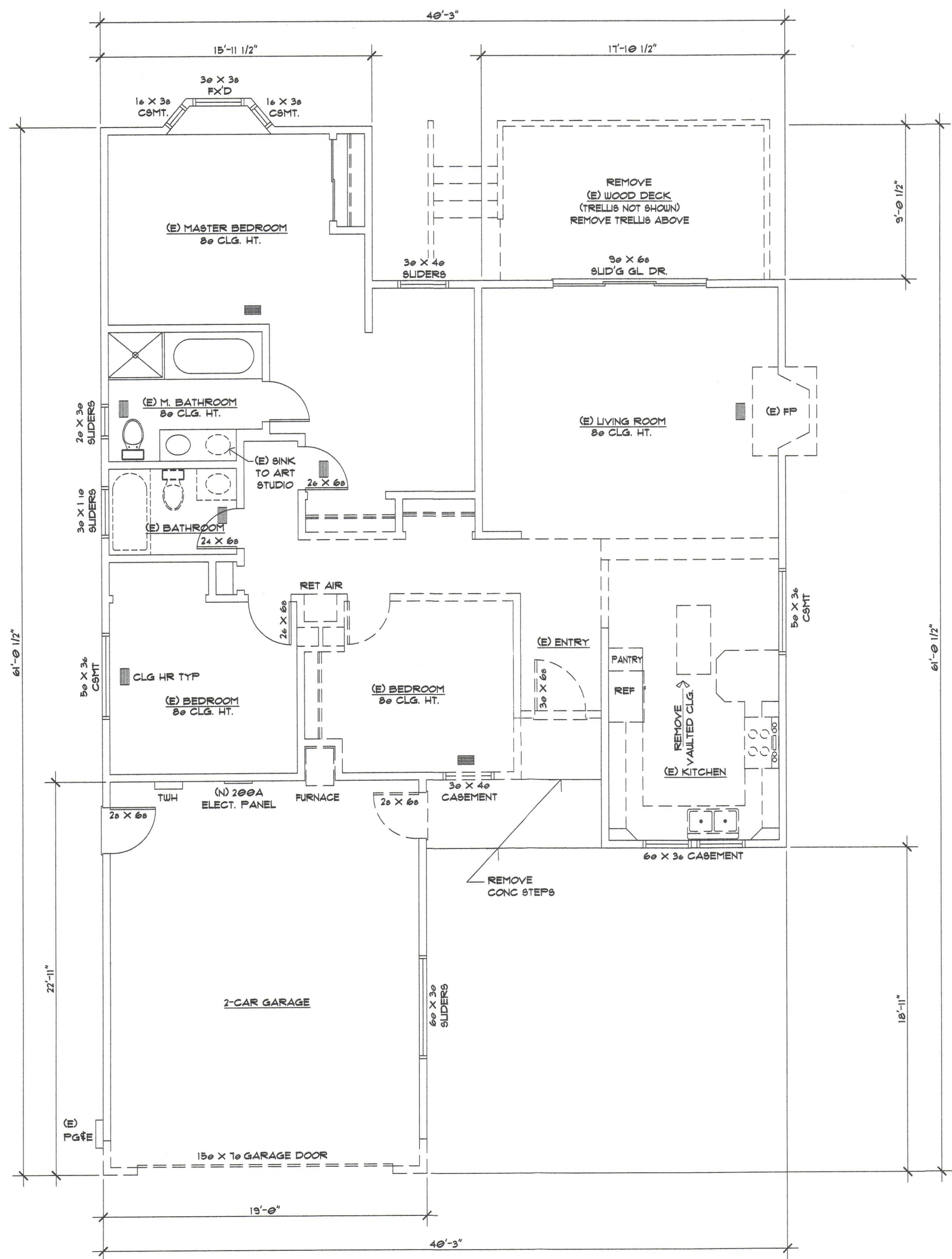

**LEGEND**

- EXISTING WALL
- REMOVE EXISTING WALL
- NEW WALL
- (E) EXISTING
- (N) NEW
- P.T.D.F. PRESSURE TREATED DOUGLAS FIR
- H.B. HOSE BIBB
- DN DOWN
- RWL RAINWATER LEADER
- NIC. NOT IN CONTRACT
- UNO UNLESS NOTED OTHERWISE
- WP WEATHERPROOF
- 6068 6'-0" x 6'-8"
- SS STAINLESS STEEL

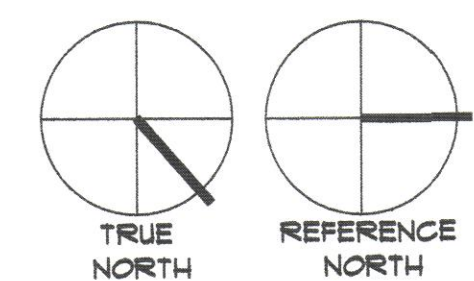
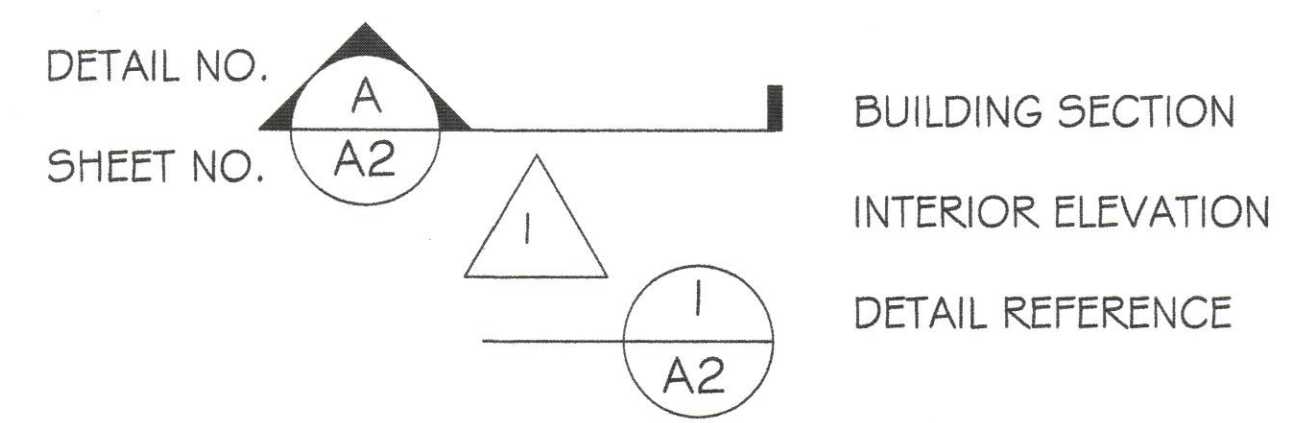

**EXISTING FLOOR PLAN - INCLUDES DEMOLITION**

1/4" = 1'-0"

REVISIONS

EDWARD C. LOVE ARCHITECT

**EDWARD C. LOVE ARCHITECT**  
 1720 MILL STREET  
 HALF MOON BAY, CA 94019  
 (650) 728-1615  
 WWW.EDWARDLOVEARCHITECT.COM

PROJECT: **UPPER FLOOR ADDITION FOR KEEGSTRA & HALL RESIDENCE**  
 420 3RD AVENUE  
 MIRAMAR (HMB), CA 94019

OWNER: **KEEGSTRA & HALL RESIDENCE**  
 420 3RD AVENUE  
 MIRAMAR (HMB), CA 94019

**(E) FLOOR PLAN & DEMO PLAN**

DATE: 1-14-15  
 SCALE: AS NOTED  
 DRAWN: RLW  
 JOB: KEEGSTRA & HALL  
 SHEET:

**A-3**

OF 11 SHEETS

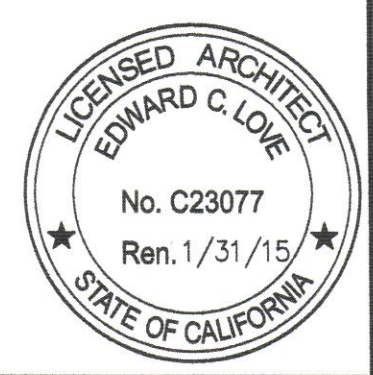

ALL DRAWINGS, SPECIFICATIONS, AND COPIES THEREOF, PREPARED AND/OR SUPPLIED BY THE ARCHITECT, SHALL REMAIN HIS PROPERTY. THEY ARE TO BE USED ONLY WITH RESPECT TO THIS PROJECT AND ARE NOT TO BE USED ON ANY OTHER PROJECT. WITH THE EXCEPTION OF ONE CONTRACT SET FOR EACH PARTY TO THE CONTRACT, SUCH DOCUMENTS ARE TO BE RETURNED OR SUITABLY ACCOUNTED FOR UPON REQUEST OF THE ARCHITECT AT THE COMPLETION OF THE WORK. SUBMISSION OR DISTRIBUTION TO MEET OFFICIAL REGULATORY REQUIREMENTS OR FOR OTHER PURPOSES IN CONNECTION WITH THE PROJECT IS NOT TO BE CONSTRUED AS PUBLICATION IN THE DEROGATION OF THE ARCHITECT'S COMMON LAW COPYRIGHT OR OTHER RESERVED RIGHTS.



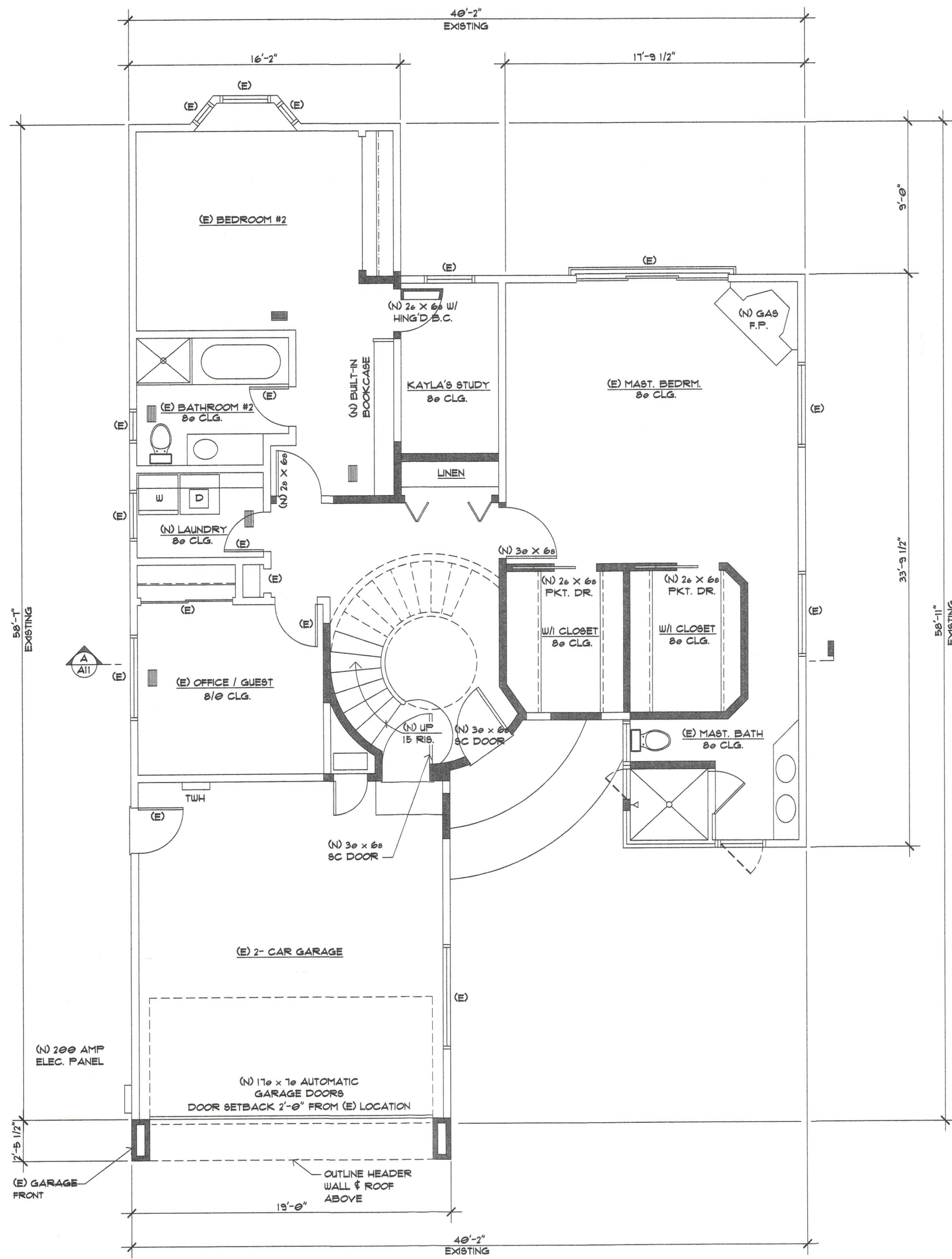

**LEGEND**

	EXISTING WALL
	REMOVE EXISTING WALL
	NEW WALL
(E)	EXISTING
(N)	NEW
P.T.D.F.	PRESSURE TREATED DOUGLAS FIR
H.B.	HOSE BIBB
DN	DOWN
RWL	RAINWATER LEADER
NIC.	NOT IN CONTRACT
UNO	UNLESS NOTED OTHERWISE
WP	WEATHERPROOF
6x6	6'-0" x 6'-8"
SS	STAINLESS STEEL

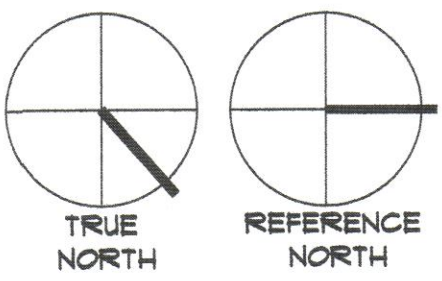
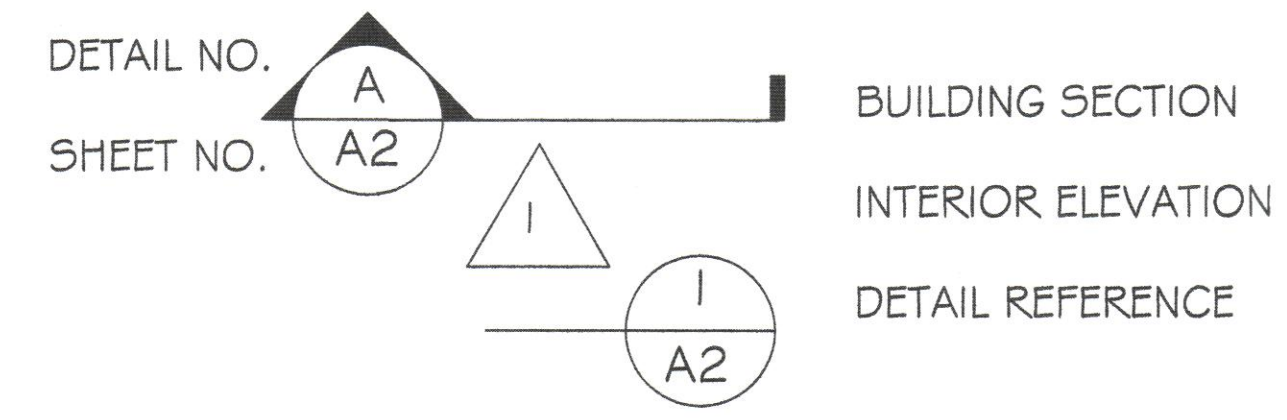

1/4" = 1'-0"

**NEW LOWER FLOOR PLAN**

REVISIONS

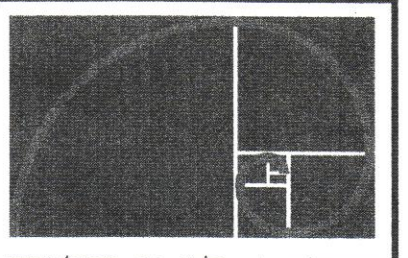

EDWARD C. LOVE • ARCHITECT

**EDWARD C. LOVE  
ARCHITECT**  
120 MILL STREET  
HALF MOON BAY, CA 94019  
(650) 728-1615  
WWW.EDWARDLOVEARCHITECT.COM

PROJECT:  
**UPPER FLOOR ADDITION  
FOR KEEGSTRA & HALL RESIDENCE**  
420 3RD AVENUE  
MIRAMAR (HMB), CA 94019

OWNER:  
**KEEGSTRA & HALL RESIDENCE**  
420 3RD AVENUE  
MIRAMAR (HMB), CA 94019

**(N) LOWER  
FLOOR  
PLAN**

DATE: 1-14-15  
SCALE: AS NOTED  
DRAWN: RLW  
JOB: KEEGSTRA & HALL  
SHEET:

**A-4**

OF 11 SHEETS

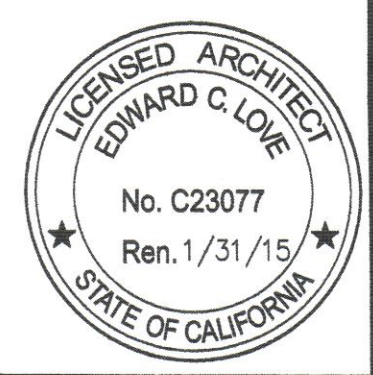

ALL DRAWINGS, SPECIFICATIONS, AND COPIES THEREOF, PREPARED AND/OR SUPPLIED BY THE ARCHITECT, SHALL REMAIN HIS PROPERTY. THEY ARE TO BE USED ONLY WITH RESPECT TO THIS PROJECT AND ARE NOT TO BE USED ON ANY OTHER PROJECT. WITH THE EXCEPTION OF ONE CONTRACT SET FOR EACH PARTY TO THE CONTRACT, SUCH DOCUMENTS ARE TO BE RETURNED OR SUITABLY ACCOUNTED FOR UPON REQUEST OF THE ARCHITECT AT THE COMPLETION OF THE WORK. SUBMISSION OR DISTRIBUTION TO MEET OFFICIAL REGULATORY REQUIREMENTS OR FOR OTHER PURPOSES IN CONNECTION WITH THE PROJECT IS NOT TO BE CONSTRUED AS PUBLICATION IN THE DEROGATION OF THE ARCHITECT'S COMMON LAW COPYRIGHT OR OTHER RESERVED RIGHTS.



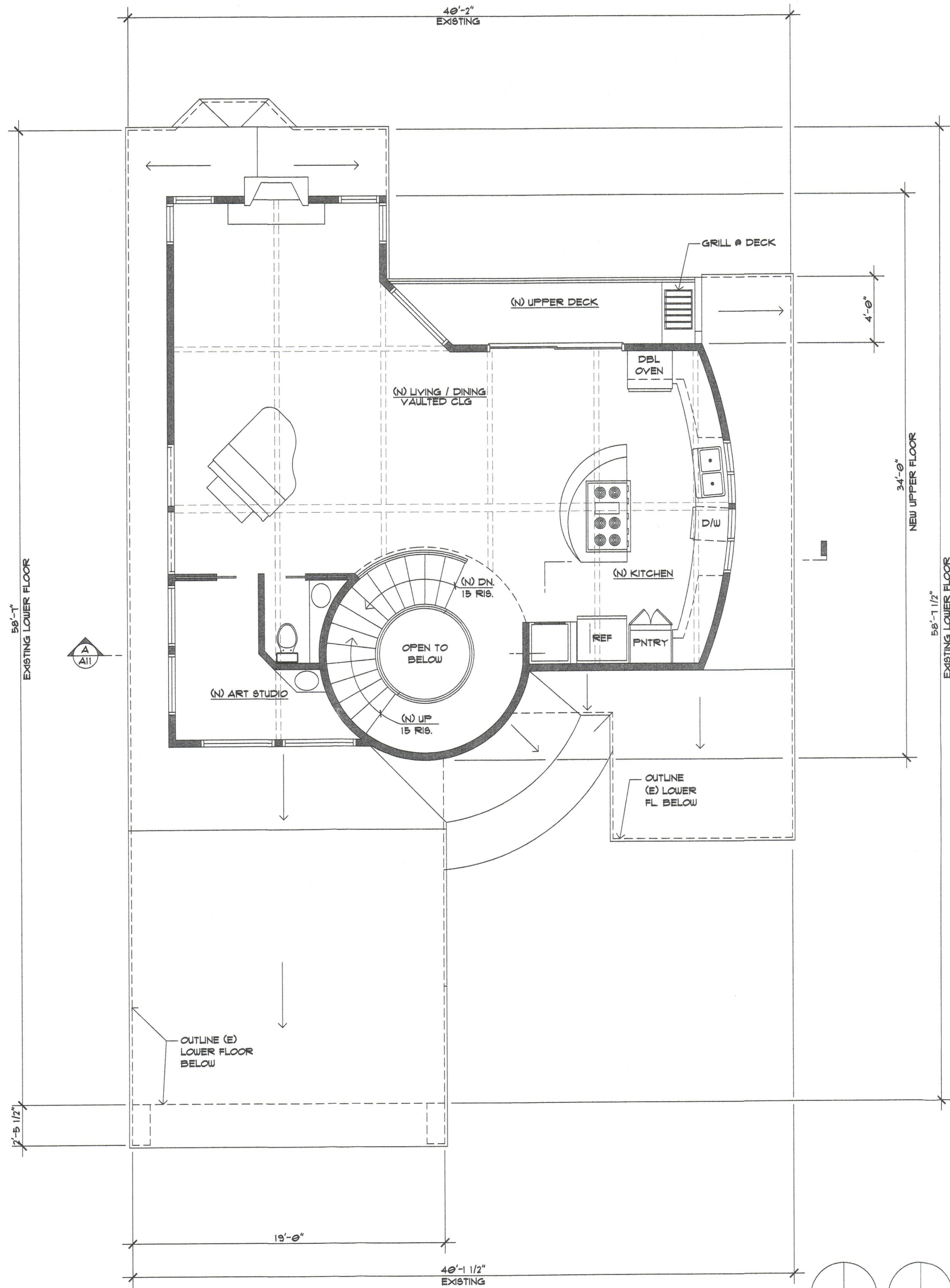

NEW UPPER FLOOR PLAN

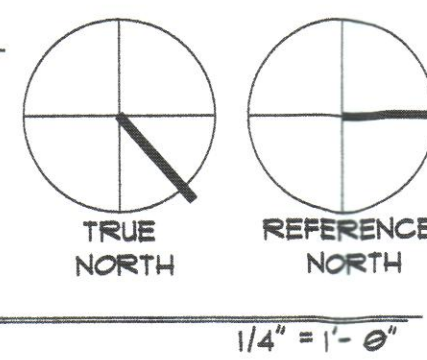

LEGEND

- EXISTING WALL
- REMOVE EXISTING WALL
- NEW WALL
- (E) EXISTING
- (N) NEW
- P.T.D.F. PRESSURE TREATED DOUGLAS FIR
- H.B. HOSE BIBB
- DN DOWN
- RWL RAINWATER LEADER
- NIC. NOT IN CONTRACT
- UNO UNLESS NOTED OTHERWISE
- WP WEATHERPROOF
- 6068 6'-0" x 6'-8"
- SS STAINLESS STEEL

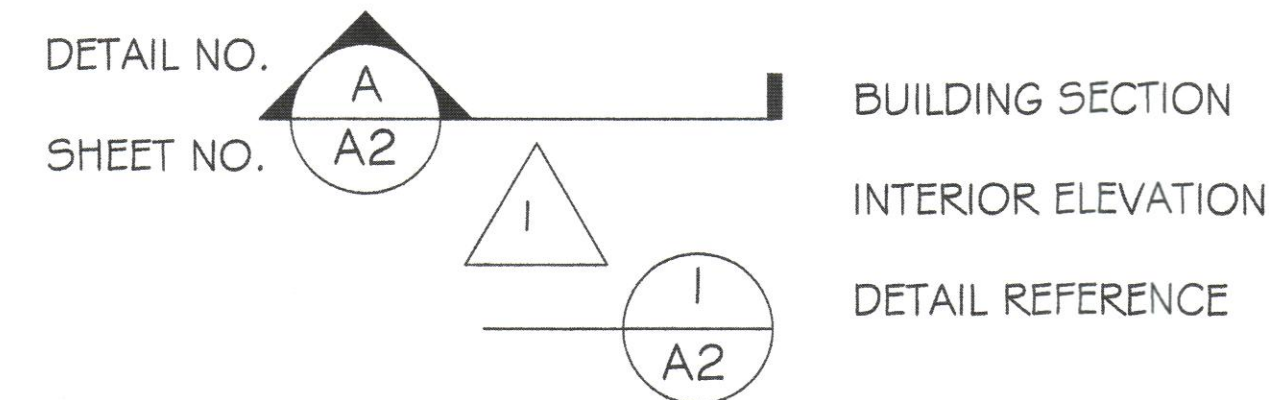

REVISIONS

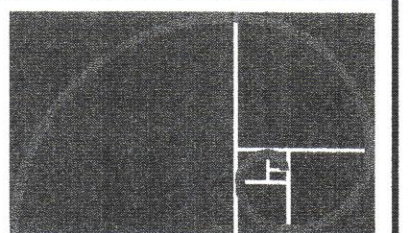
EDWARD C. LOVE ARCHITECT

EDWARD C. LOVE  
ARCHITECT  
170 MILL STREET  
HALF MOON BAY, CA 94019  
(650) 728-1615  
WWW.EDWARDLOVEARCHITECT.COM

PROJECT:  
UPPER FLOOR ADDITION  
FOR KEEGSTRA & HALL RESIDENCE  
420 3RD AVENUE  
MIRAMAR (HMB), CA 94019

OWNER:  
KEEGSTRA & HALL RESIDENCE  
420 3RD AVENUE  
MIRAMAR (HMB), CA 94019

(N) UPPER  
FLOOR  
PLAN

DATE: 1-14-15  
SCALE: AS NOTED  
DRAWN: RLW  
JOB: KEEGSTRA & HALL  
SHEET:

A-5  
OF 11 SHEETS

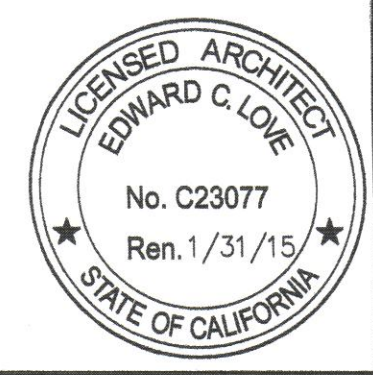



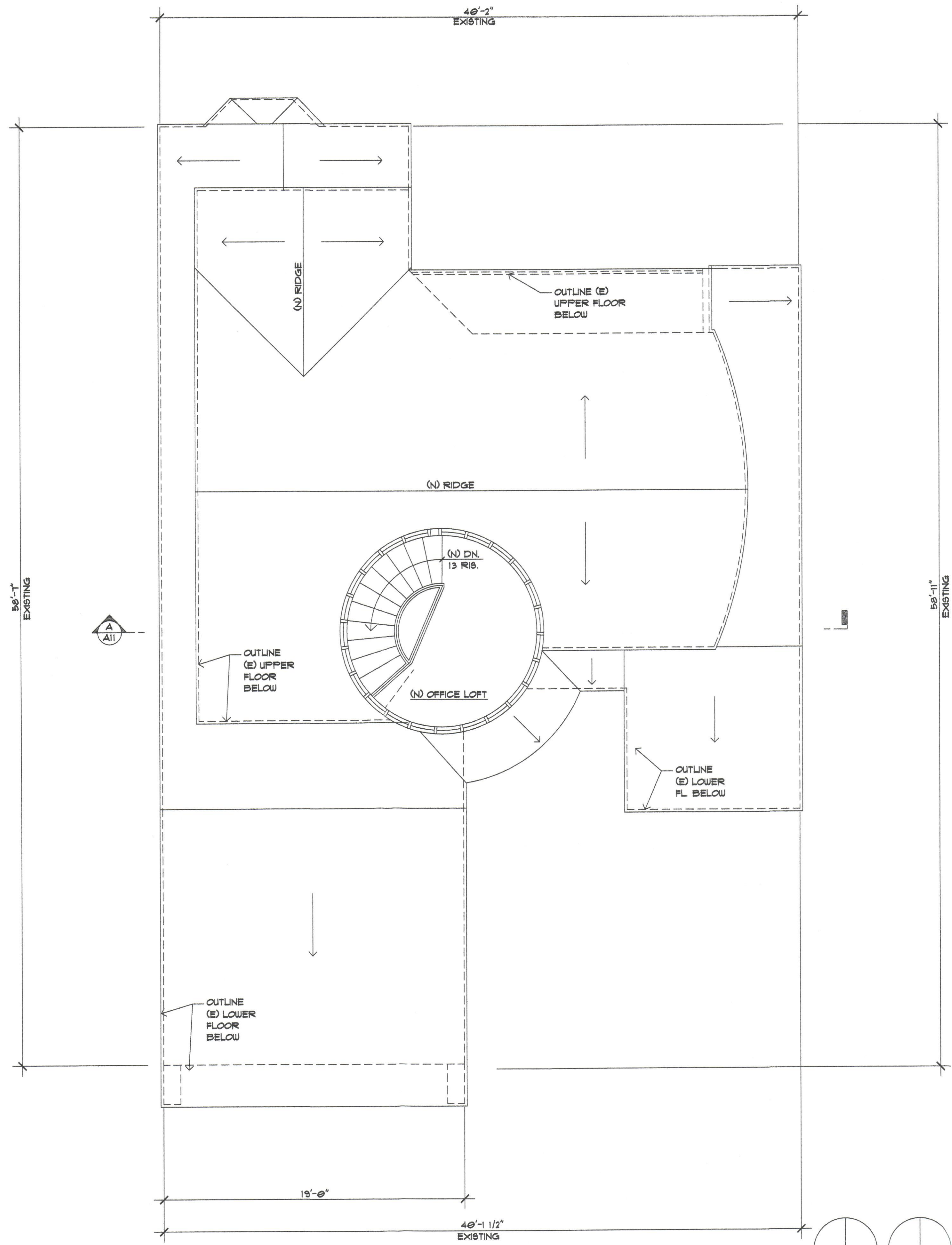

**LEGEND**

- EXISTING WALL
- REMOVE EXISTING WALL
- NEW WALL
- (E) EXISTING
- (N) NEW
- P.T.D.F. PRESSURE TREATED DOUGLAS FIR
- H.B. HOSE BIBB
- DN DOWN
- RWL RAINWATER LEADER
- NIC. NOT IN CONTRACT
- UNO UNLESS NOTED OTHERWISE
- WP WEATHERPROOF
- 6068 6'-0" x 6'-8"
- SS STAINLESS STEEL

- DETAIL NO. A BUILDING SECTION
- SHEET NO. A2 INTERIOR ELEVATION
- 1 DETAIL REFERENCE
- 1  
A2

**NEW UPPER FLOOR LOFT PLAN**

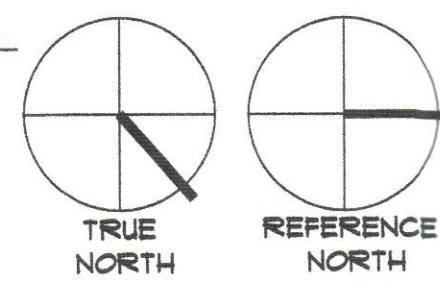

1/4" = 1'-0"

REVISIONS

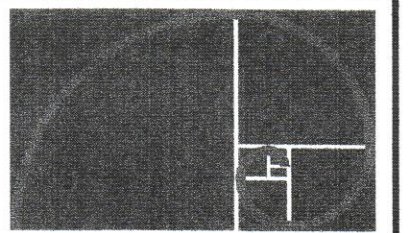

EDWARD C. LOVE ARCHITECT

**EDWARD C. LOVE ARCHITECT**  
 120 MILL STREET  
 HALF MOON BAY, CA 94019  
 (650) 728-1615  
 WWW.EDWARDLOVEARCHITECT.COM

**UPPER FLOOR ADDITION**  
 FOR KEEGSTRA & HALL RESIDENCE  
 420 3RD AVENUE  
 MIRAMAR (HMB), CA 94019

**KEEGSTRA & HALL RESIDENCE**  
 420 3RD AVENUE  
 MIRAMAR (HMB), CA 94019

**(2) 3RD FLOOR- WRITER'S EYRIE PLAN**

DATE: 1-14-15  
 SCALE: AS NOTED  
 DRAWN: RLW  
 JOB: KEEGSTRA & HALL  
 SHEET:

**A-6**

OF 11 SHEETS

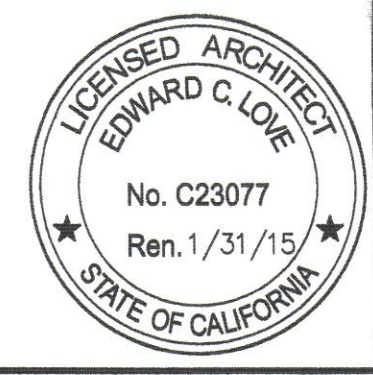



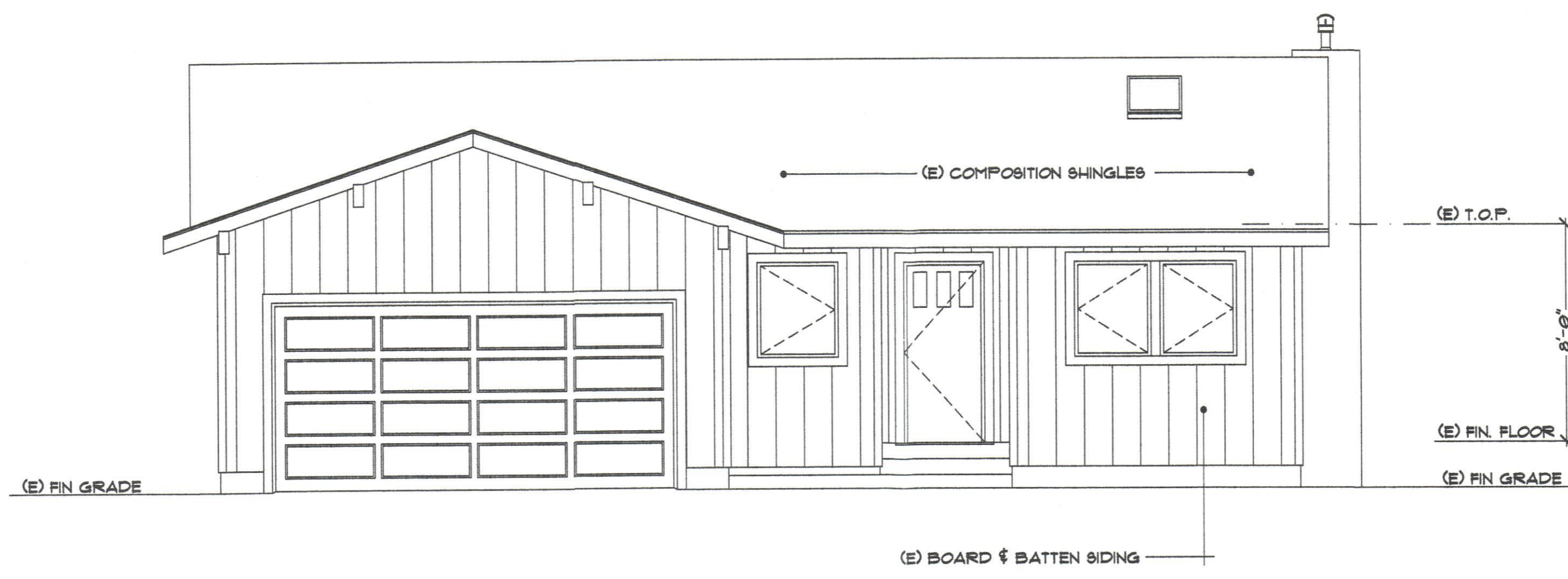

(E) EAST ELEVATION

1/4" = 1'-0"

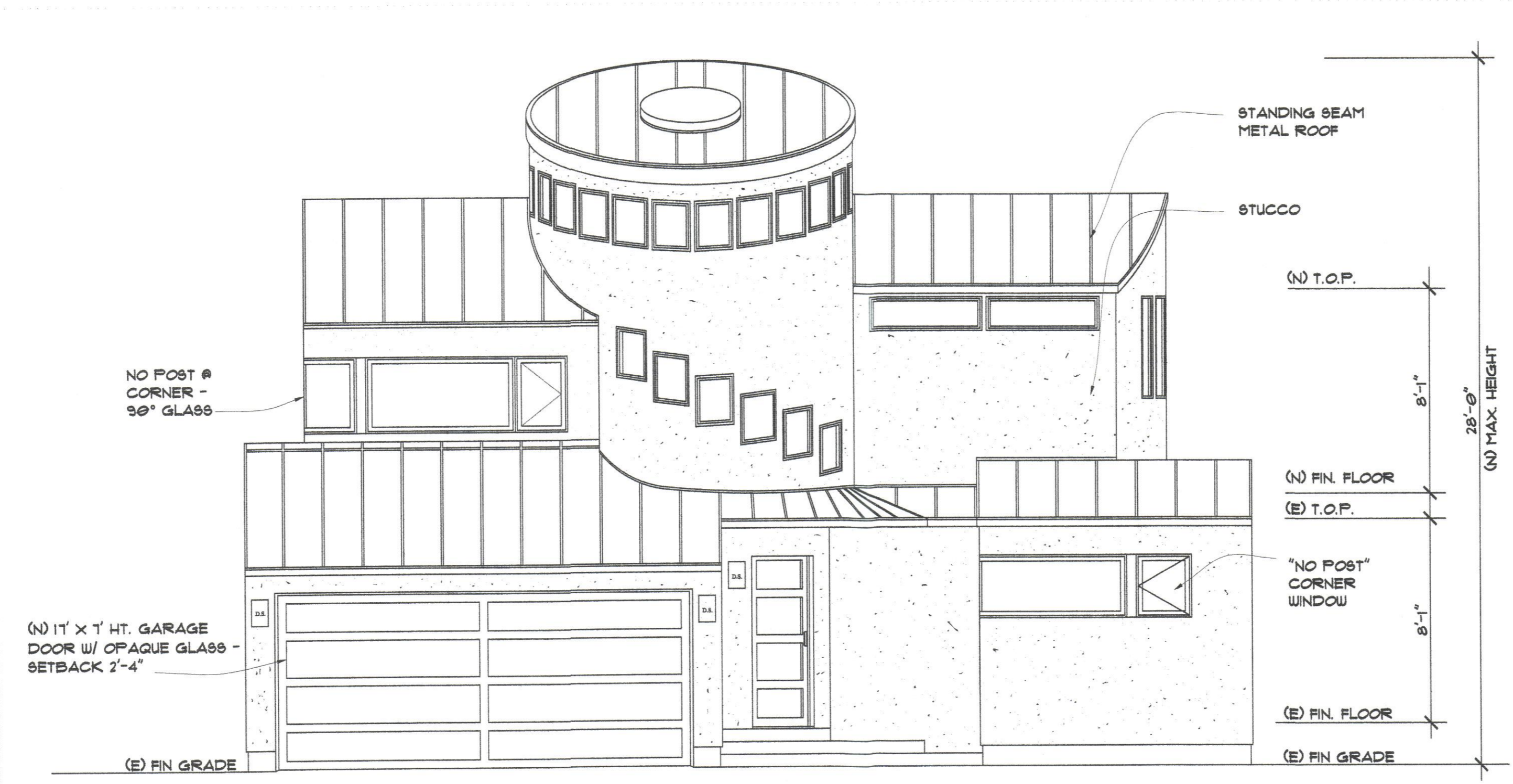

(N) EAST ELEVATION

1/4" = 1'-0"

REVISIONS

**EDWARD C. LOVE**  
ARCHITECT  
120 MILL STREET  
HALF MOON BAY, CA 94019  
(650) 728-1615  
WWW.EDWARDLOVEARCHITECT.COM

**UPPER FLOOR ADDITION**  
FOR KEEGSTRA & HALL RESIDENCE  
420 3RD AVENUE  
MIRAMAR (HMB), CA 94019

OWNER:  
**KEEGSTRA & HALL RESIDENCE**  
420 3RD AVENUE  
MIRAMAR (HMB), CA 94019

**EXISTING & NEW EAST ELEVATIONS**

DATE: 1-14-15  
SCALE: AS NOTED  
DRAWN: RLW  
JOB: KEEGSTRA & HALL  
SHEET:

**A-1**  
OF 11 SHEETS

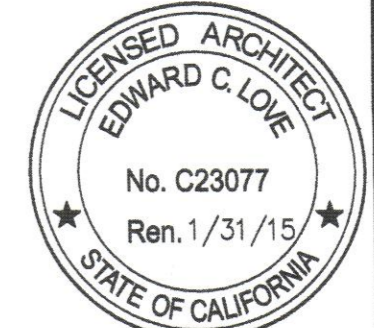



REVISIONS

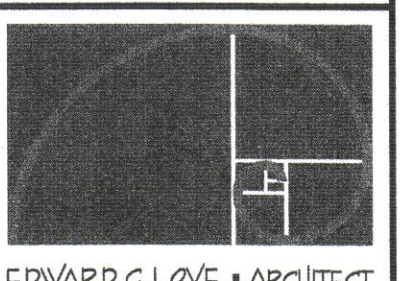

EDWARD C. LOVE • ARCHITECT

**EDWARD C. LOVE  
ARCHITECT**  
120 MILL STREET  
HALF MOON BAY, CA 94019  
(650) 728-1615  
WWW.EDWARDLOVEARCHITECT.COM

**UPPER FLOOR ADDITION  
FOR KEEGSTRA & HALL RESIDENCE**  
420 3RD AVENUE  
MIRAMAR (HMB), CA 94019

**KEEGSTRA & HALL RESIDENCE**  
420 3RD AVENUE  
MIRAMAR (HMB), CA 94019

**(E) & (N)  
NORTH  
ELEVATIONS**

DATE: 1-14-15  
SCALE: AS NOTED  
DRAWN: RLW  
JOB: KEEGSTRA & HALL  
SHEET:

**A-8**  
OF 11 SHEETS

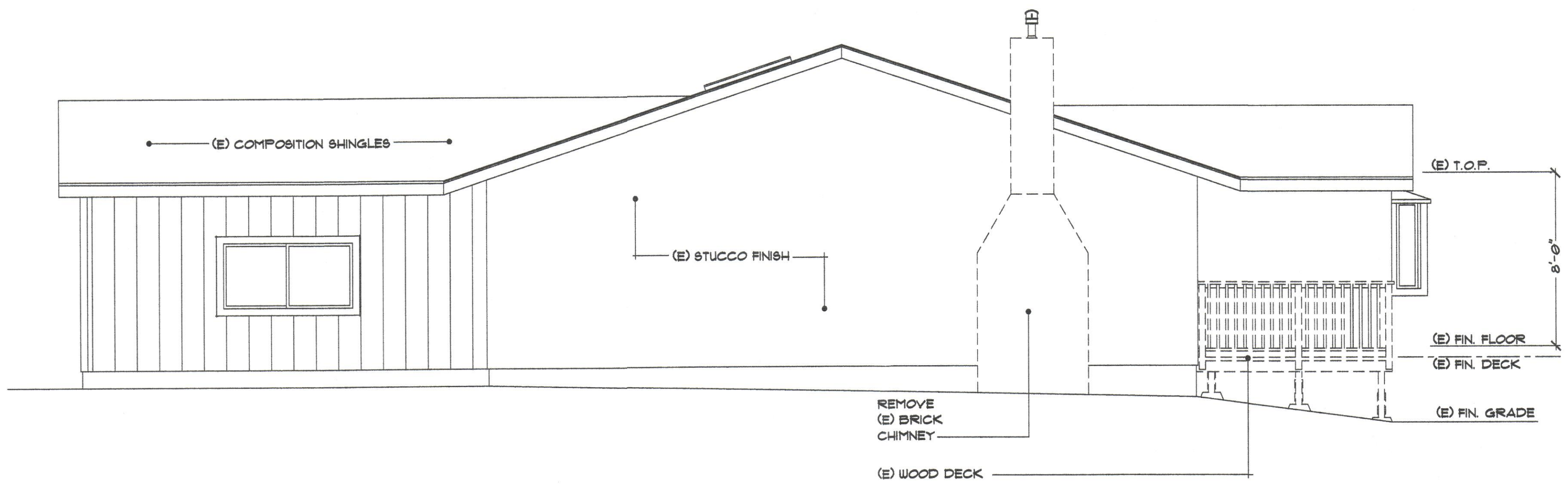

**(E) NORTH ELEVATION**

1/4" = 1'-0"

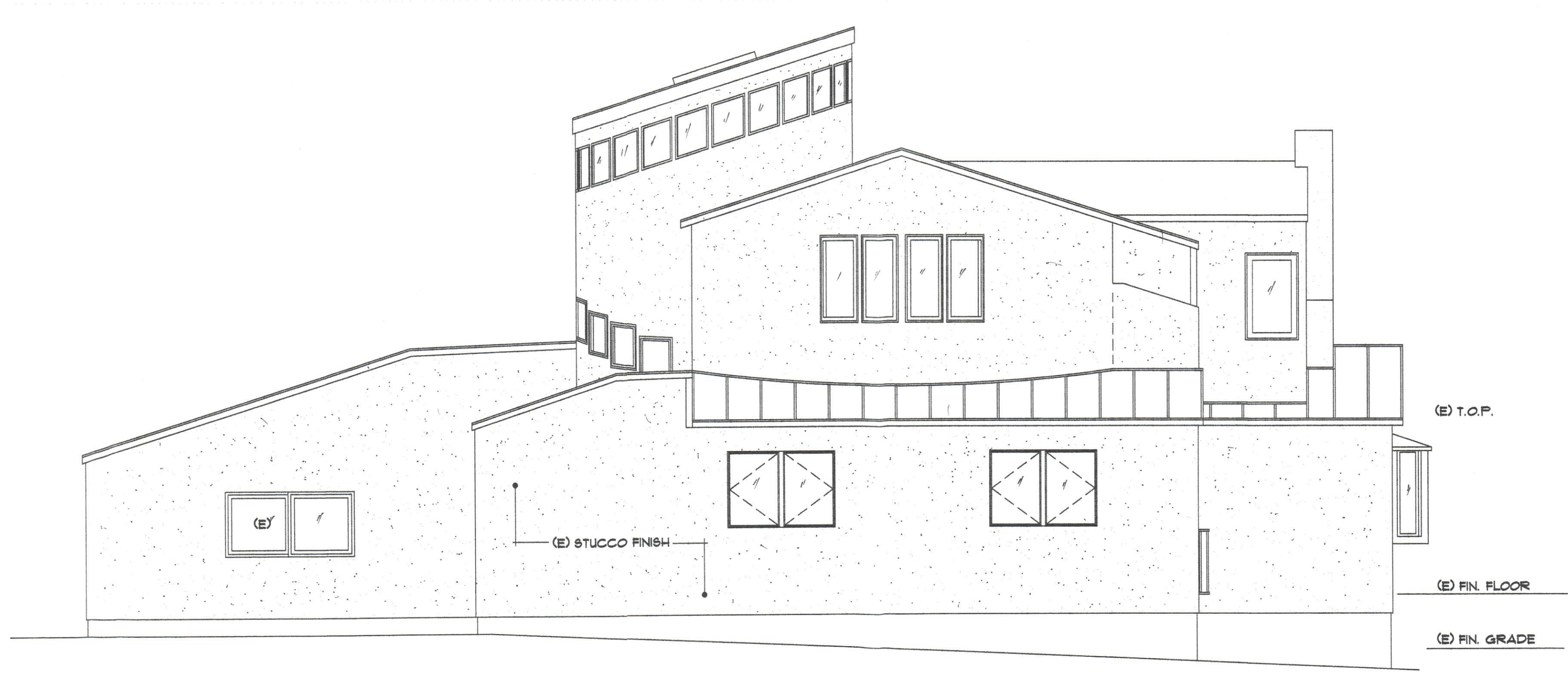

**(N) NORTH ELEVATION**

1/4" = 1'-0"

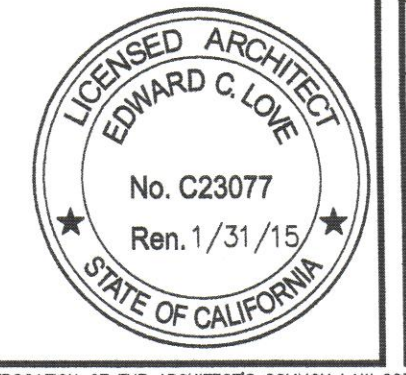



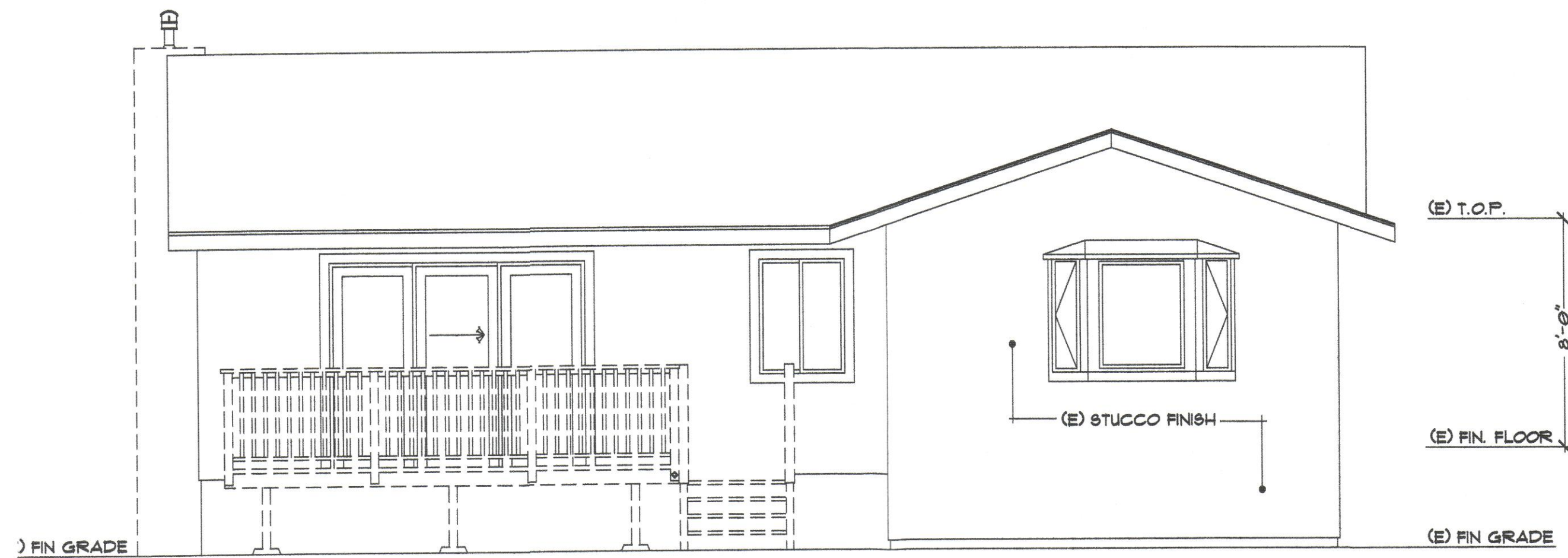

(E) WEST ELEVATION

1/4" = 1'-0"



(N) WEST ELEVATION

1/4" = 1'-0"

REVISIONS

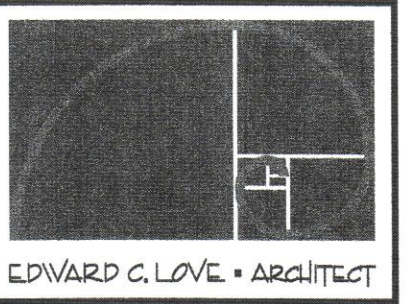

EDWARD C. LOVE • ARCHITECT

**EDWARD C. LOVE  
ARCHITECT**  
120 MILL STREET  
HALF MOON BAY, CA 94019  
(650) 728-1615  
WWW.EDWARDLOVEARCHITECT.COM

PROJECT:  
**UPPER FLOOR ADDITION  
FOR KEEGSTRA & HALL RESIDENCE**  
420 3RD AVENUE  
MIRAMAR (HMB), CA 94019

OWNER:  
**KEEGSTRA & HALL RESIDENCE**  
420 3RD AVENUE  
MIRAMAR (HMB), CA 94019

(E) & (N)  
WEST  
ELEVATION

DATE: 1-14-15  
SCALE: AS NOTED  
DRAWN: RLW  
JOB: KEEGSTRA & HALL  
SHEET:

**A-9**  
OF 11 SHEETS

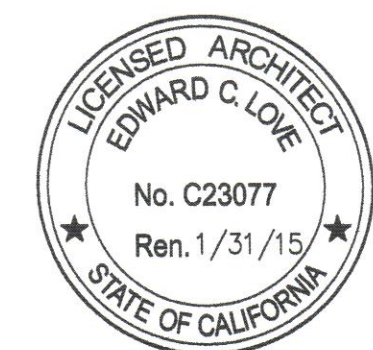



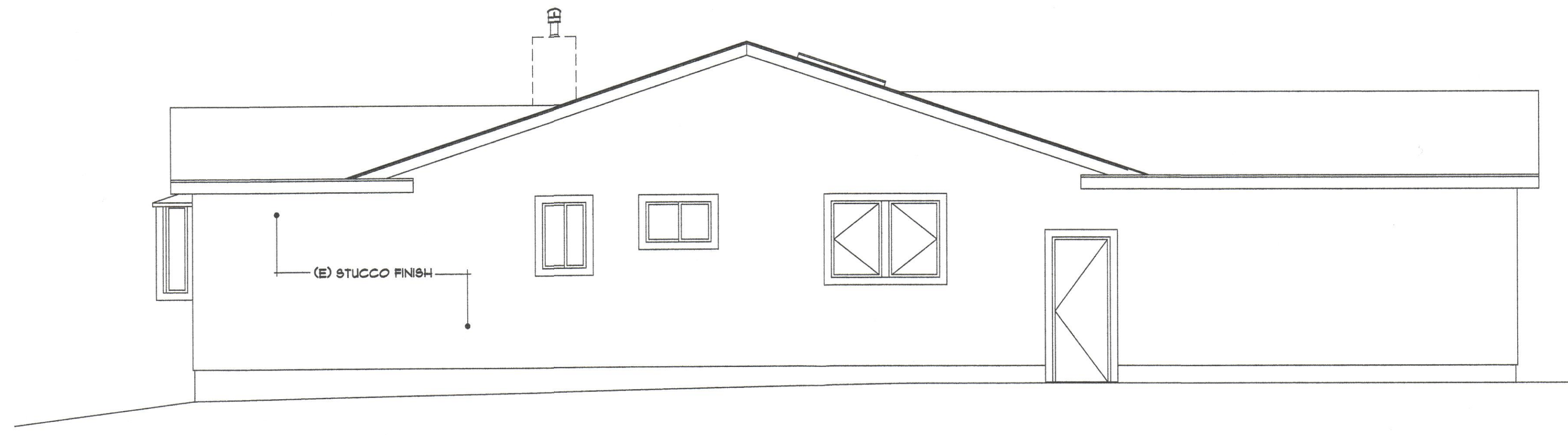

(E) SOUTH ELEVATION

1/4" = 1'-0"

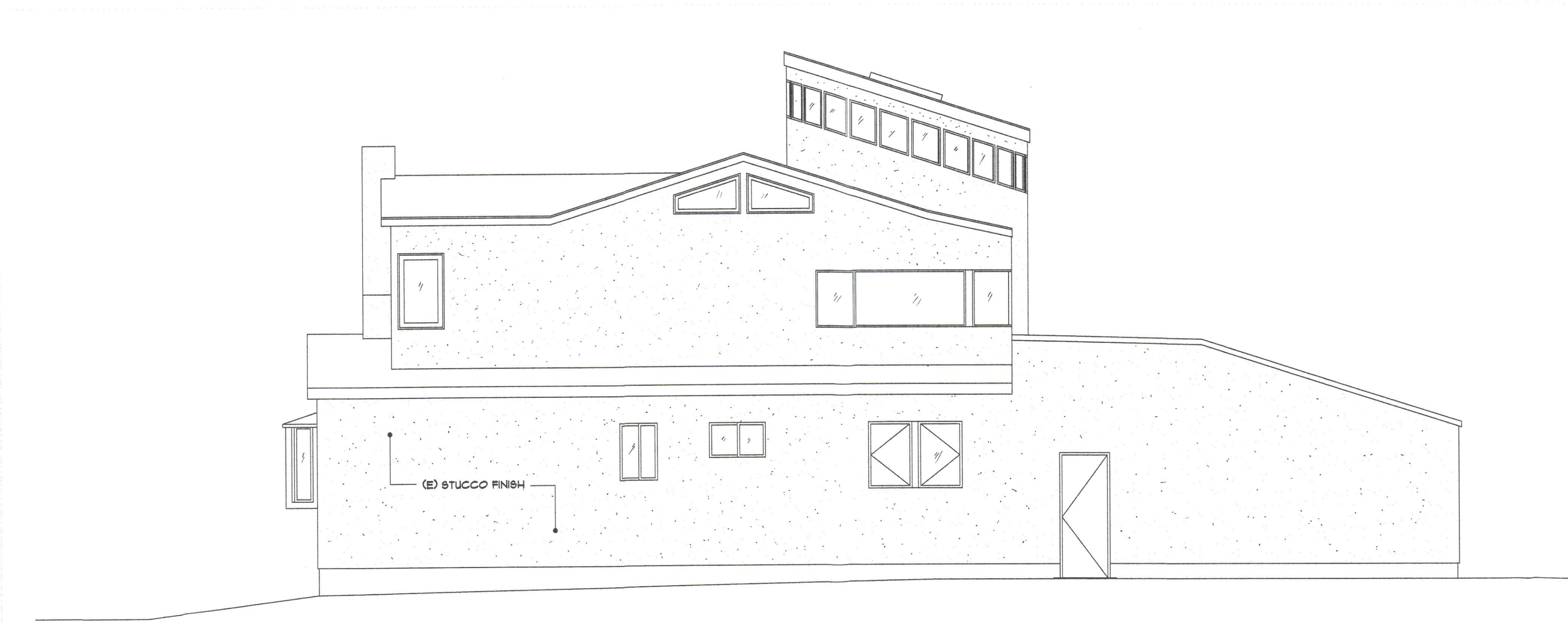

(N) SOUTH ELEVATION

1/4" = 1'-0"

REVISIONS

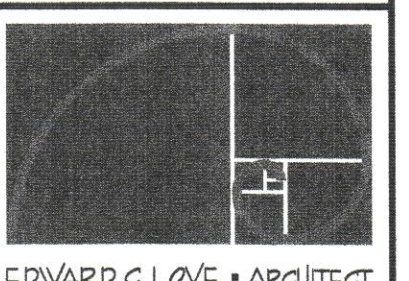

EDWARD C. LOVE ARCHITECT

**EDWARD C. LOVE  
ARCHITECT**  
120 MILL STREET  
HALF MOON BAY, CA 94019  
(650) 728-1615  
WWW.EDWARDLOVEARCHITECT.COM

**UPPER FLOOR ADDITION  
FOR KEEGSTRA & HALL RESIDENCE**  
420 3RD AVENUE  
MIRAMAR (HMB), CA 94019

**KEEGSTRA & HALL RESIDENCE**  
420 3RD AVENUE  
MIRAMAR (HMB), CA 94019

**NEW  
EXTERIOR  
WEST &  
SOUTH  
ELEVATIONS**

DATE: 1-14-15  
SCALE: AS NOTED  
DRAWN: RLW  
JOB: KEEGSTRA & HALL  
SHEET:

**A-10**  
OF 11 SHEETS

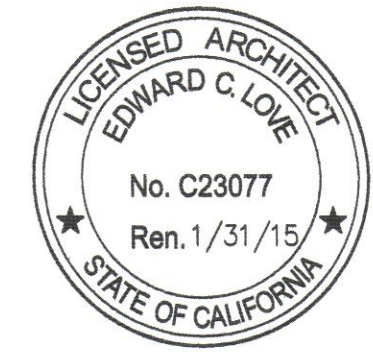



REVISIONS

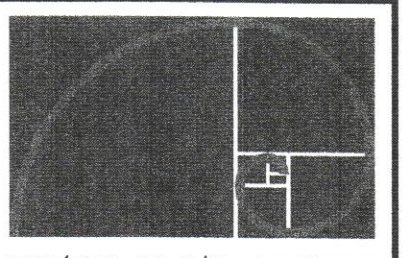

EDWARD C. LOVE ARCHITECT

**EDWARD C. LOVE  
ARCHITECT**  
 120 MILL STREET  
 HALF MOON BAY, CA 94019  
 (650) 728-1615  
 WWW.EDWARDLOVEARCHITECT.COM

PROJECT:  
**UPPER FLOOR ADDITION  
 FOR KEEGSTRA & HALL RESIDENCE**  
 420 3RD AVENUE  
 MIRAMAR (HMB), CA 94019

OWNER:  
**KEEGSTRA & HALL RESIDENCE**  
 420 3RD AVENUE  
 MIRAMAR (HMB), CA 94019

**SECTIONS**

DATE: 1-14-15  
 SCALE: AS NOTED  
 DRAWN: RLW  
 JOB: KEEGSTRA & HALL  
 SHEET: **A-11**  
 OF 11 SHEETS

- T.O. Chimney  
+25'-5"
- T.O. Ridge  
+23'-5"
- 2nd Floor CLG  
+17'-5"
- 1st Floor CLG  
8'-0"
- First Floor  
+0'-0"

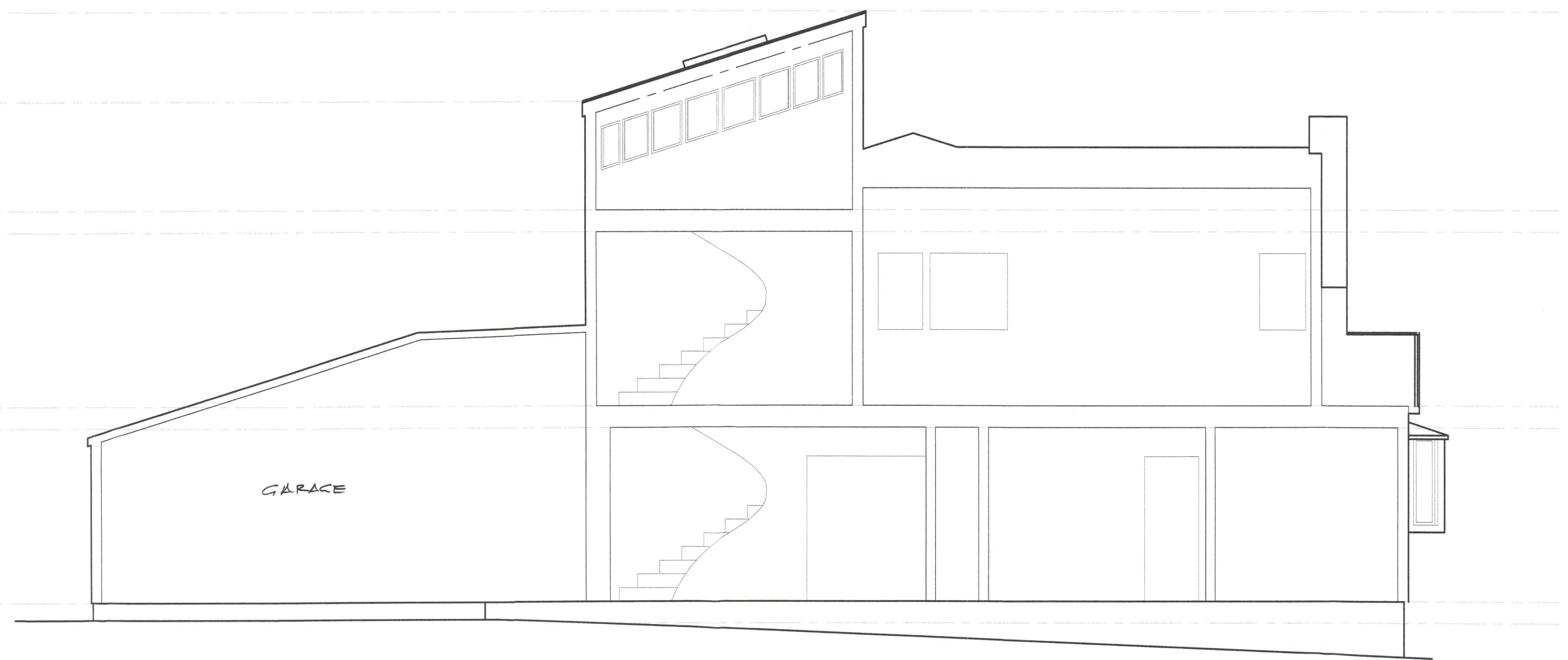

GARAGE

